

INSTALLATION GUIDELINE

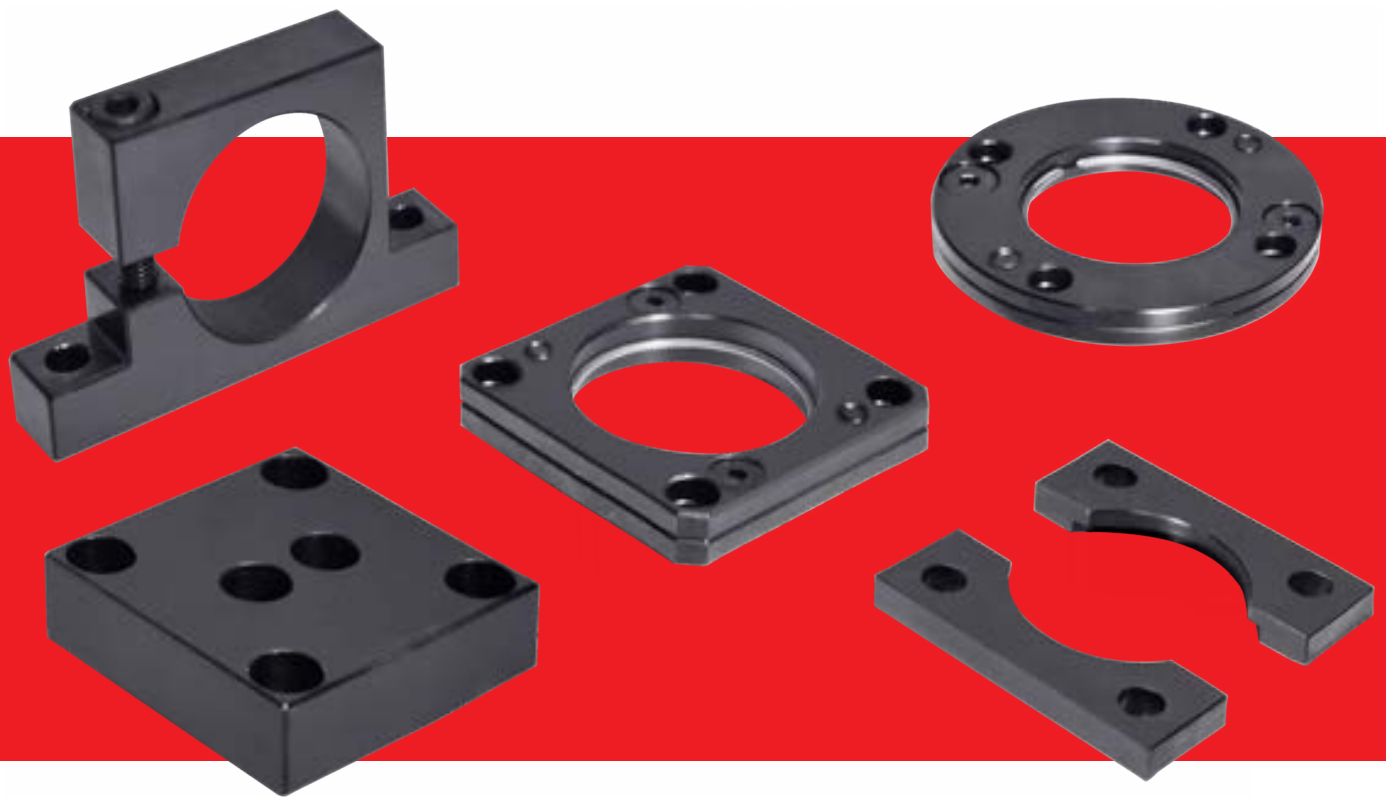

INSTALLATION GUIDELINE



- IT** Un corretto fissaggio dei cilindri ad azoto previene danni ai prodotti e gravi pericoli agli operatori.
- EN** A correct fixing of the gas springs prevents damages to products and serious dangers to operators.
- DE** Die richtige Befestigung der Gasdruckfeder verhindert Schäden an den Produkten und ernsthafte Gefahren für das Personal.
- FR** La fixation correcte du ressort à gaz évite des dommages aux produits et des dangers graves pour les opérateurs.
- ES** Una correcta fijación del cilindro de gas previene daños a los productos y graves peligros a los operadores.
- PT** Uma correta fixação do cilindro pode prevenir danos ao produto e também ao operador.

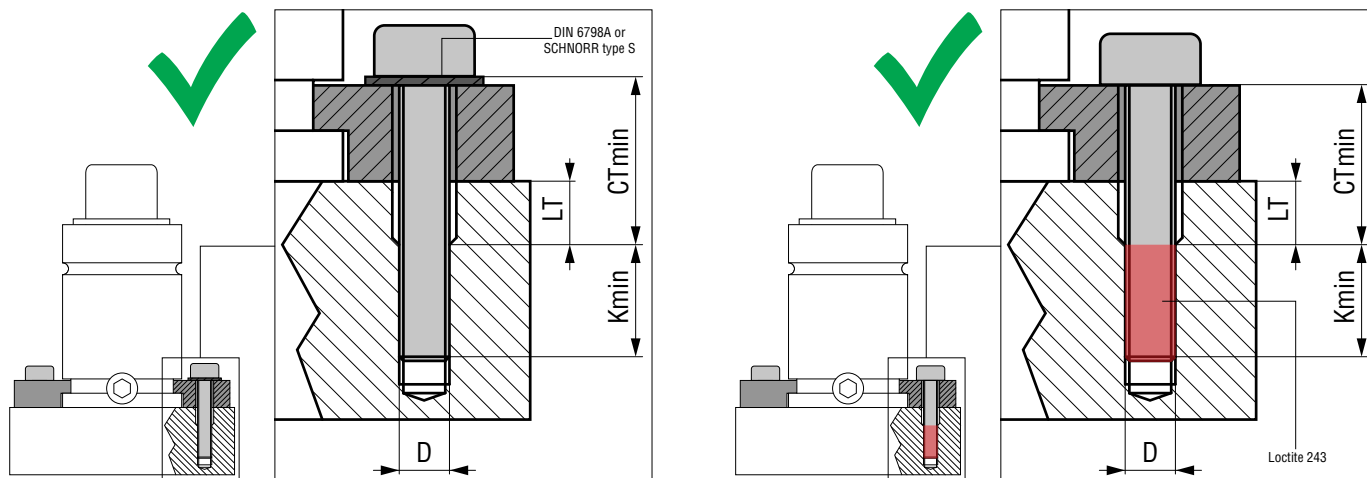

CTmin	Kmin	LT
Lunghezza libera (min. 2 x D)	Minimo impegno viti (acciaio = min. 1.5 x D, ghisa = min. 2 x D)	Allargamento per garantire CTmin
Free length (min. 2 x D)	Minimum thread engagement (steel = min. 1.5 x D, cast iron = min. 2 x D)	Widening to ensure CTmin
Klemmlänge (min. 2 x D)	Mindest-Einschraublänge (Stah = min. 1.5 x D, Guss = min. 2 x D)	Bohrung zur Gewährleistung der CTmin
Longueur libre (min. 2 x D)	Longueur minimum à visser (acier = min. 1.5 x D, fonte = min. 2 x D)	Élargissement pour assurer CTmin
Longitud libre (min. 2 x D)	Longitud mínima de roscado (acero = min. 1.5 x D, fundición = min. 2 x D)	Margen para garantizar CTmin
Comprimento livre (min. 2 x D)	Comprimento mínimo roscado (aço 1,5 x D – Fundido 2,0 x D)	Alívio para garantir o CT min

- IT** Utilizzare sempre apposito frenafiletti e/o rondelle di sicurezza su tutte le viti di fissaggio. (Non rappresentate nei disegni delle pagine seguenti).
- EN** Always use the suitable threadlocker and/or safety washers on all fixing screws. (They are not represented in the drawings in the following pages of the catalog).
- DE** Verwenden Sie immer geeignete Schraubensicherungen und/oder Sicherungsscheiben an allen Befestigungsschrauben. (Nicht in den Zeichnungen auf den folgenden Seiten dargestellt).
- FR** Utilisez toujours le frein filet approprié et/ou les rondelles de sécurité sur toutes les vis de fixation. (Ils ne sont pas représentés sur les dessins dans les pages suivantes du catalogue).
- ES** Utilice siempre un adhesivo fijador de roscas adecuado y/o arandelas de seguridad en todos los tornillos de fijación. (No están representados en los dibujos de las páginas siguientes).
- PT** Sempre utilizar o trava roscas e/ou arruela de segurança em todos os parafusos de fixação (não estão representados nas próximas páginas do catalogo).



Rondelle di sicurezza - Safety Washers
Sicherungsscheiben - Rondelles de sécurité
Arandelas de seguridad - Arruela de segurança

<p>Only for ML, MP, MQ series</p> <p>Conical spring washer provided by Special Springs</p>	<p>DIN 6798A or SCHNORR type S</p>
--	------------------------------------

- IT** L' uso di viti di classe superiore alla 8.8, come 9.8, 10.9 e 12.9, è sempre possibile. Si raccomanda di NON SUPERARE i valori della coppia di serraggio indicati per la classe 8.8 per qualsiasi classe di viti utilizzata (vedi pag. 207).
- EN** It is always possible to use screws belonging to Classes higher than 8.8, such as 9.8, 10.9 and 12.9. Do NOT EXCEED the values of the tightening torque valid for Class 8.8 for any of the screw's Classes you may use (see page 207 of the Catalogue).
- DE** Die Verwendung von Schrauben von höheren Klassen als 8.8, wie 9.8, 10.9 und 12.9 ist immer möglich. Es wird empfohlen, die für die Klasse 8.8 angegebenen Anziehdrehmomente für alle verwendeten Schraubenklassen nicht zu überschreiten.
- FR** L' est toujours possible d'utiliser des vis appartenant aux classes supérieures à 8.8, telles que 9.8, 10.9 et 12.9. NE PAS DÉPASSER les valeurs du couple de serrage indiquées pour la classe 8.8 pour n'importe quelle classe de résistance que vous allez utiliser (voir page 207 du catalogue).
- ES** El uso de tornillos de calidad superior a 8.8, como 9.8, 10.9 y 12.9 está permitido. Se recomienda NO EXCEDER el par de apriete indicado para la clase 8.8 para cualquier calidad de tornillos utilizados (consulte la página 207).
- PT** Sempre é possível usar parafusos pertencentes a classes superiores a 8.8, como 9.8, 10.9 e 12.9. NÃO SUPERAR os valores do torque recomendado para os parafusos da classe 8.8, mesmo que esteja utilizando parafusos com classes diferentes, (ver página 207).

- IT** Cilindro ad azoto con fori di fissaggio in cui il valore di A è maggiore del valore D (esempio SC3000 con fori di fissaggio M8x13).
- EN** Gas spring with fixing holes for which value A is bigger than value D (e.g. SC3000 with fixing holes M8x13).
- DE** Gasdruckfeder mit Befestigungsbohrungen bei denen der Wert A größer als der Wert D ist (Beispiel SC3000 mit Befestigungsbohrungen M8x13).
- FR** Ressort à gaz avec trous de fixation dans lequel la valeur A est supérieure à la valeur D (par exemple, SC3000 avec trous de fixation M8x13).
- ES** Cilindro de gas con agujeros de fijación en el que el valor A es mayor que el valor D (ejemplo SC3000 con agujeros de fijación M8x13).
- PT** Cilindros com furos de fixação que a medida A é maior que a medida D (ex. SC3000 com furos de fixação M8x13).

Installation Example: $A > D$

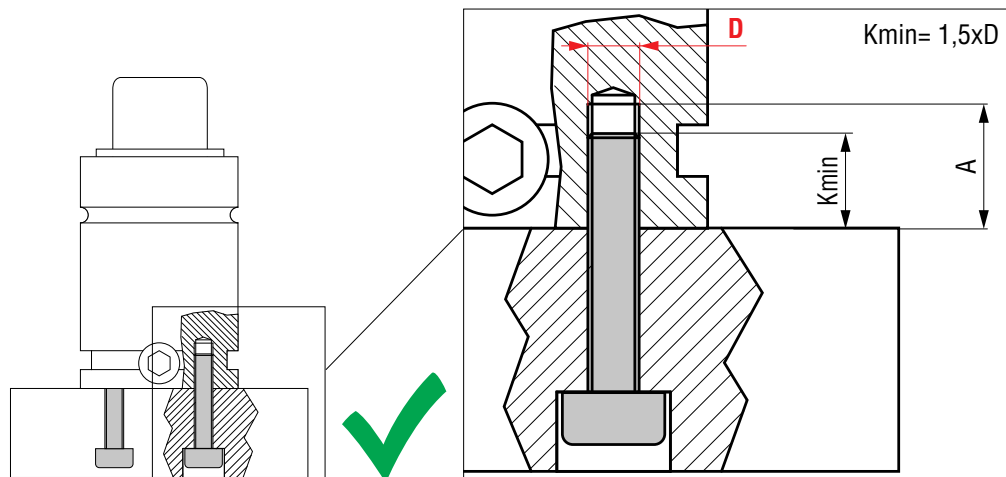

- IT** Cilindro ad azoto in cui il valore A è minore del valore D (esempio RV1000 con fori di fissaggio M8x6). Attenzione: in questi casi utilizzare viti con lunghezza tale da impegnare l'intera profondità utile di fissaggio.
- EN** Gas spring with fixing holes for which value A is smaller than value D (e.g. RV1000 with fixing holes M8x6). In such cases, be careful to use screws with a length long enough to employ the whole usable fixing depth.
- DE** Gasdruckfeder bei der der Wert A kleiner als der Wert D ist (Beispiel RV1000 mit Befestigungsbohrungen M8x6). Achtung: Verwenden Sie in diesen Fällen Schrauben mit einer Länge, die über die gesamte Einschraublänge reicht.
- FR** Ressort à gaz avec trous de fixation dans lequel la valeur A est inférieure à la valeur D (par exemple, RV1000 avec trous de fixation M8x6). Dans ce cas, veuillez utiliser des vis suffisamment longues pour utiliser toute la profondeur de fixation utilisable.
- ES** Cilindro de gas en el que el valor A es menor que el valor D (ejemplo RV1000 con agujeros de fijación M8x6). Atención: en estos casos utilizar tornillos con una longitud que permita utilizar toda la profundidad útil de fijación.
- PT** Cilindros que a medida A é menor que a medida D (ex. RV1000 com furos de fixação M8x6). Neste caso, atentar para que o comprimento do parafuso seja suficiente para garantir o comprimento mínimo de roscado na placa.

Installation Example: $A \leq D$

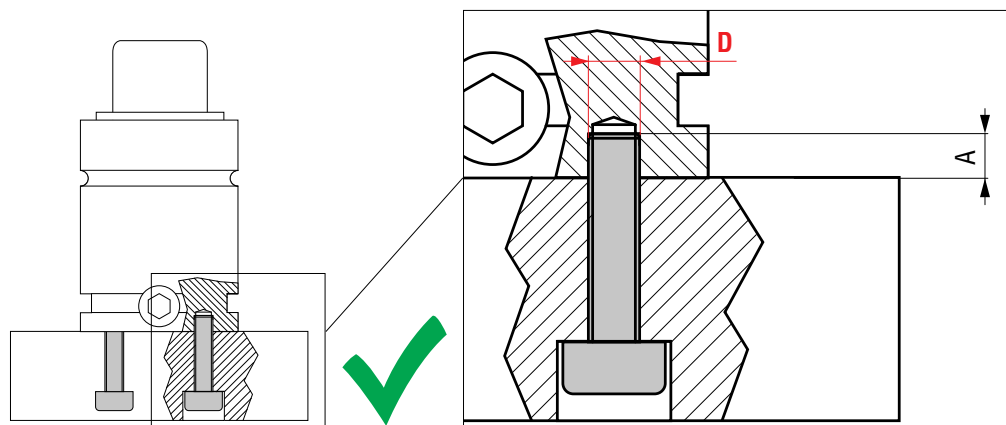

INSTALLATION GUIDELINE

IT Le viti di fissaggio non devono mai essere sollecitate direttamente dal carico agente sul cilindro ad azoto.

EN Fixing screws shall never be directly strained by the load acting on the gas spring.

DE Die Befestigungsschrauben dürfen niemals direkt durch die auf die Gasdruckfeder wirkende Last belastet werden.



FR Les vis de fixation ne doivent jamais être directement sollicitées par la charge agissant sur le ressort à gaz.

ES Los tornillos de fijación nunca deben recibir directamente la carga que se aplica sobre el cilindro de gas.

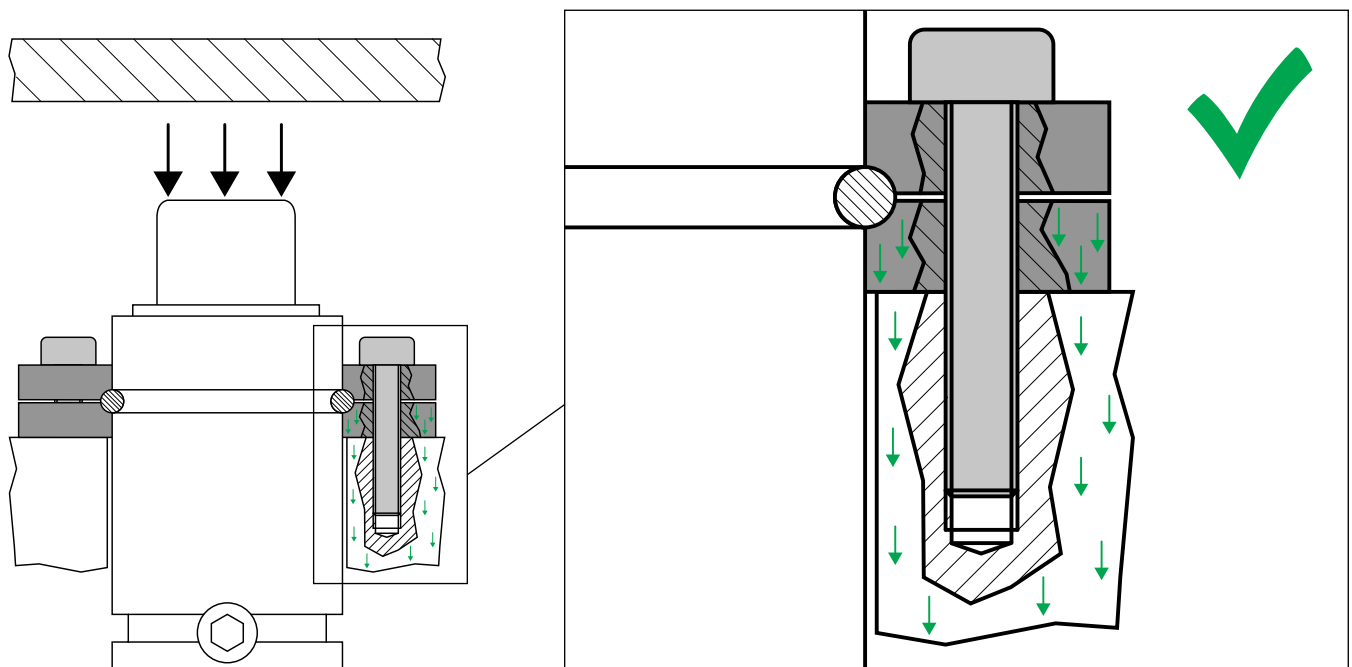
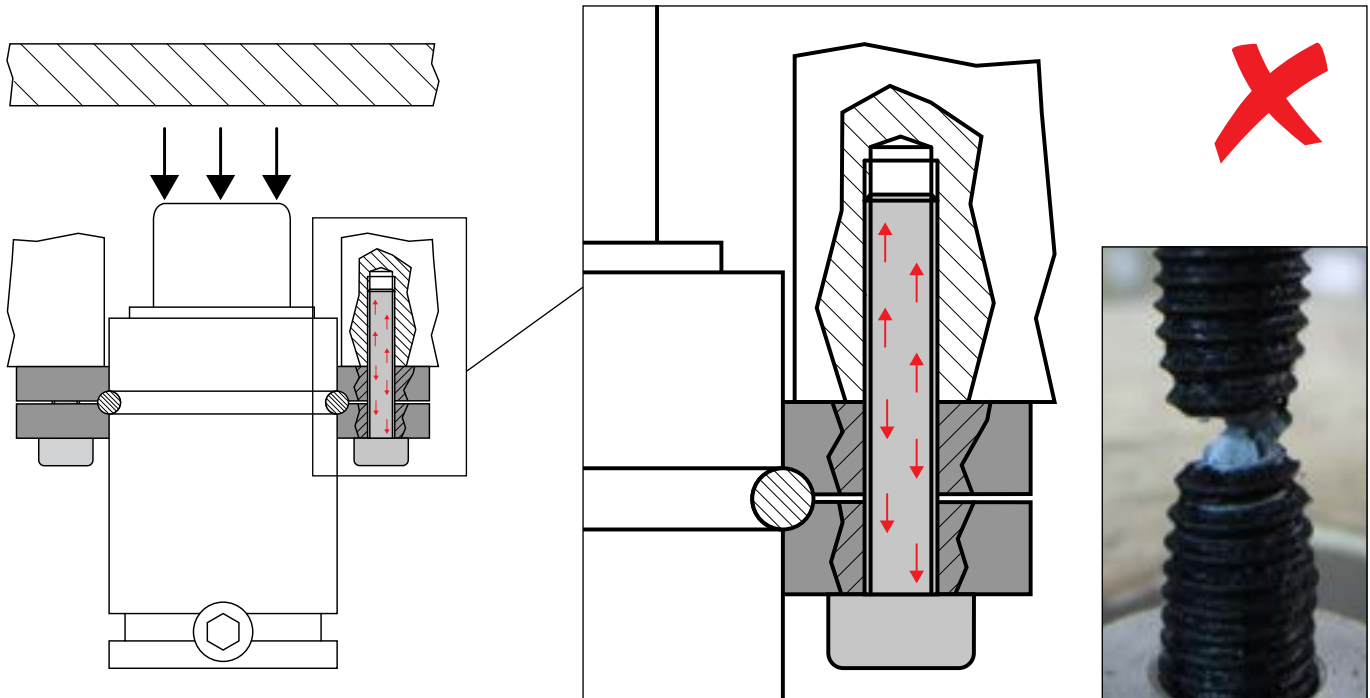
PT Os parafusos de fixação jamais devem receber diretamente a carga do cilindro.



- IT** Rispettare le coppie di serraggio prescritte e verificare sempre lo stato dei cilindri ad azoto e dei fissaggi ad ogni intervento sullo stampo.
- EN** Respect the specified tightening torques and verify always the condition of gas springs and fixings at each intervention on the die.
- DE** Beachten Sie die vorgeschriebenen Anziehdrehmomente und überprüfen Sie bei jedem Eingriff am Werkzeug den Zustand der Gasdruckfedern und Befestigungen.
- FR** Respectez les couples de serrage spécifiés et vérifiez les conditions des ressorts à gaz et des fixations à chaque intervention sur le moule.
- ES** Respete los pares de apriete indicados y verifique el estado de los cilindros de gas y de las fijaciones en cada intervención en el troquel.
- PT** Respeitar o torque dos parafusos especificado e a cada parada para manutenção da ferramenta deve ser verificado as condições dos cilindros e das flanges.

	UNI EN ISO 21269:2007 class ≥ 8.8	M5	M6	M8	M10	M12	M 16
	Torque force	6 Nm	10 Nm	24 Nm	50 Nm	84 Nm	205 Nm

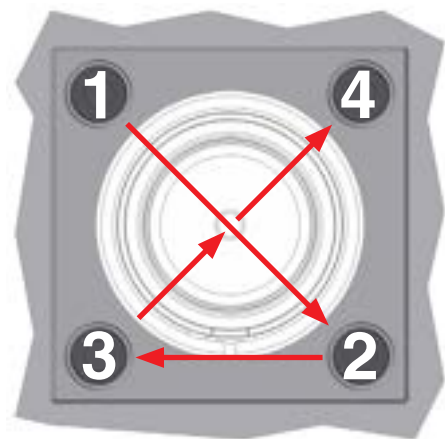
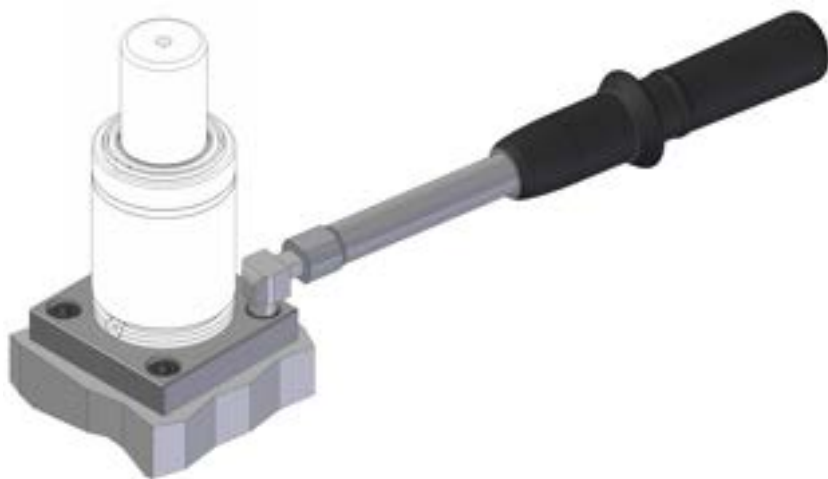

- IT** Serrare tutte le viti di fissaggio seguendo l'ordine a croce (1, 2, 3, 4) applicando la coppia di serraggio corretta. In questo modo il cilindro ad azoto sarà perfettamente posizionato.
- EN** Tighten all fixing screws by following the order shown in the image (1, 2, 3, 4) and by applying the correct tightening torque. In doing so, the gas springs will be perfectly positioned.
- DE** Alle Befestigungsschrauben über Kreuz in der Reihenfolge 1, 2, 3, 4 (s. Bild) mit dem richtigen Anziehdrehmoment anziehen. Auf diese Weise wird die Gasdruckfeder perfekt positioniert.
- FR** Serrez toutes les vis de fixation en respectant l'ordre indiqué sur l'image (1, 2, 3, 4) et en appliquant le couple de serrage approprié. Ce faisant, les ressorts à gaz seront parfaitement positionnés.
- ES** Apriete todos los tornillos de fijación siguiendo el orden que se muestra en la imagen (1, 2, 3, 4) y aplicando el par de apriete correcto. Al hacerlo, los resortes de gas estarán perfectamente posicionados.
- PT** Os parafusos devem ser apertados seguindo a ordem do desenho (1,2,3,4) e aplicado o torque correto. Dessa forma os cilindros estarão perfeitamente fixados.

INSTALLATION GUIDELINE - DROP-IN



Esempi di installazione - Installation examples - Montagebeispiele - Exemples d'installation - Ejemplos de instalación - Exemplo de instalação

- IT** I cilindri ad azoto devono essere sempre installati perpendicolarmente rispetto alla direzione di trasmissione della forza.
- EN** Gas springs must always be installed perpendicular to the direction of force transmission.
- DE** Die Gasdruckfedern müssen immer lotrecht hinsichtlich der Richtung der Kraftübertragung eingebaut werden.
- FR** Les ressorts à gaz doivent toujours être installés perpendiculairement à la direction de la transmission de la force.
- ES** Los cilindros de gas siempre deben ser instalados perpendicularmente respecto a la dirección de transmisión de la fuerza.
- PT** Os Cilindros de Nitrogenio devem sempre ser instalados perpendicular a direção da força de acionamento.

- IT** I fori di alloggiamento in cui vengono installati i cilindri ad azoto devono sempre essere provvisti di fori di drenaggio.
- EN** The housing holes where the gas springs are installed must always have drain holes.
- DE** Die Gehäusebohrungen, in den die Gasdruckfedern eingebaut werden, müssen immer ein Drainage Loch haben.
- FR** Les logements de l'outil où sont installés les vérins à gaz doivent toujours avoir des trous de drainage.
- ES** Los agujeros en los que se instalan los cilindros siempre deben tener agujeros de drenaje.
- PT** Os alojamentos dos cilindros devem sempre ter um furo para drenagem.

DROP - IN

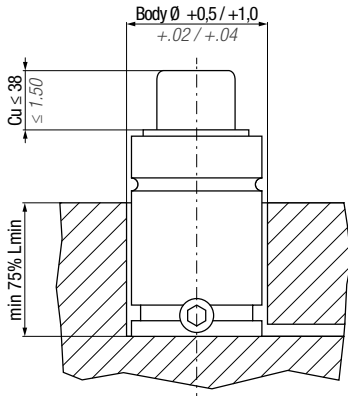

Installation in a flat-end hole.

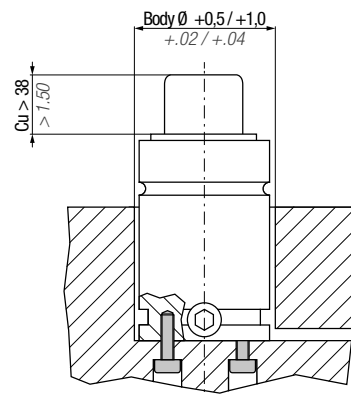

Installation in a flat-end hole with bottom fixing screws.

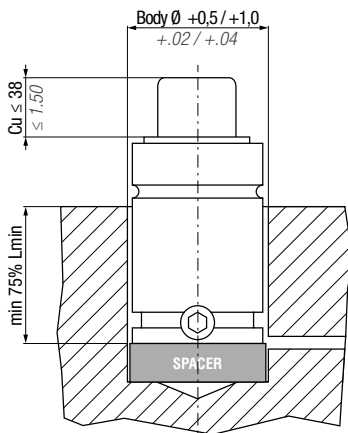

Installation in a flat-end hole with spacer.

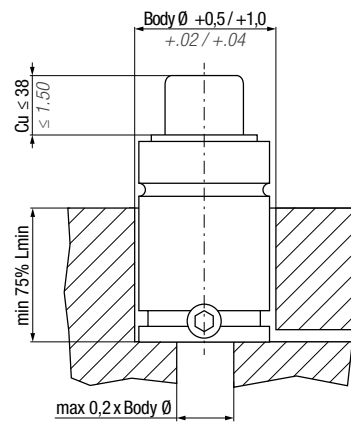

Max throughout bottom hole dimension for drop-in installation.

INSTALLATION GUIDELINE - DROP-IN

Esempi di installazione - Installation examples - Montagebeispiele - Exemples d'installation - Ejemplos de instalación - Exemplo de instalação

DROP - IN (ML, MP, MQ p. 221 - 222)

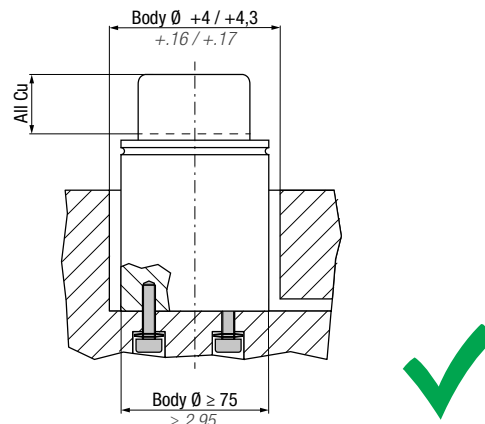
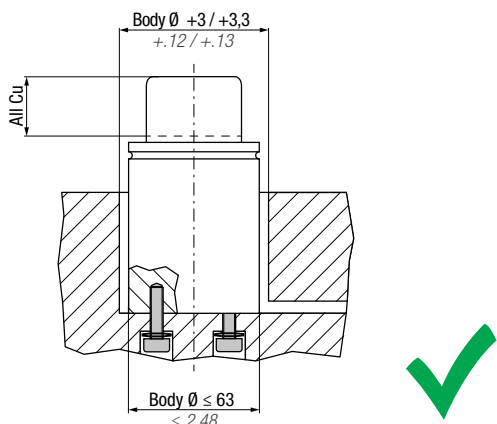

Installation in a flat-end hole with bottom fixing screws.

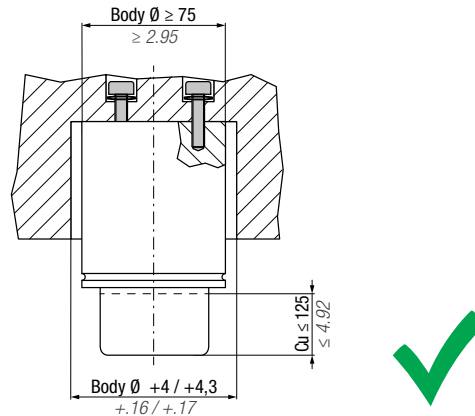
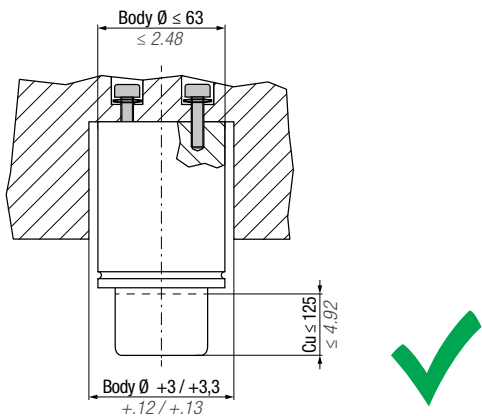

Installation in a flat-end hole with fixing screws in upside down position.

DROP - IN

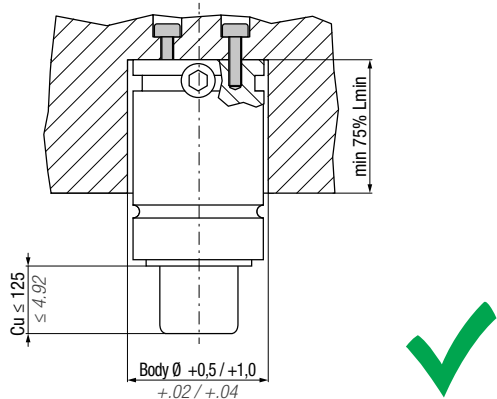

Installation in a flat-end hole with fixing screws in upside down position.

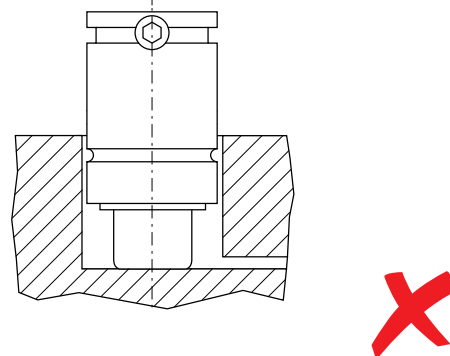

Installation NOT allowed due to excessive body wearing.

INSTALLATION GUIDELINE - BOTTOM MOUNT



Esempi di installazione - Installation examples - Montagebeispiele - Exemples d'installation - Ejemplos de instalación - Exemplo de instalação

BODY THREADED HOLES

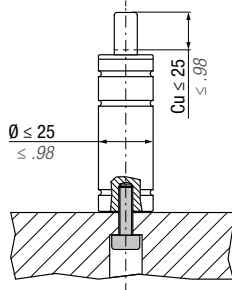

Installation with single fixing screw.

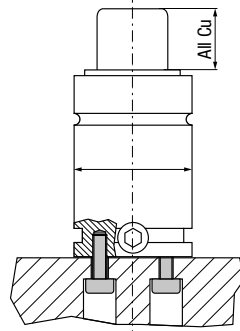

Installation with bottom fixing screws.

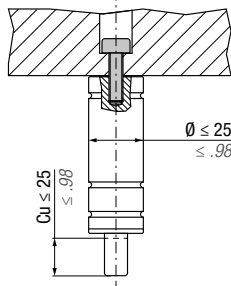
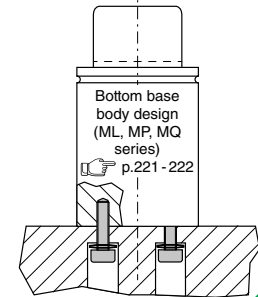

Installation with single fixing screw in upside down position.

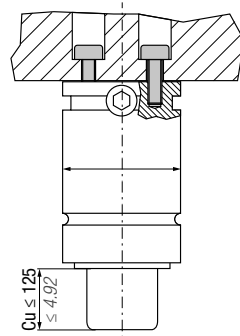

Installation with bottom fixing screws in upside down position.

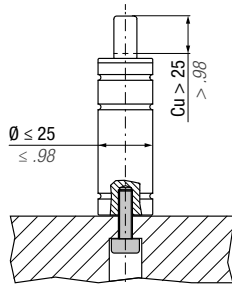
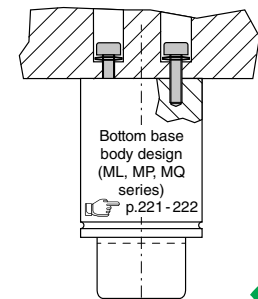

Installation NOT allowed due to excessive stress on gas spring bottom.

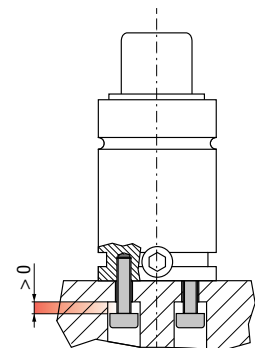
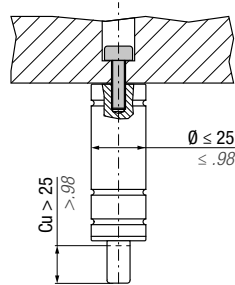

Installation NOT allowed due to incorrect screw length.

Esempi di installazione - Installation examples - Montagebeispiele - Exemples d'installation - Ejemplos de instalación - Exemplo de instalação

FB - FBA - FBB - FBC - FBD - FBF

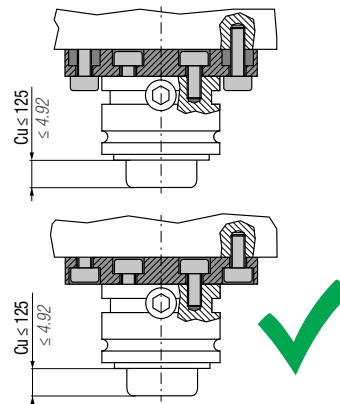
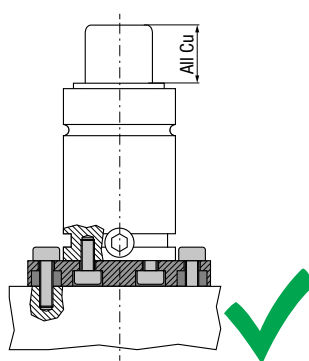
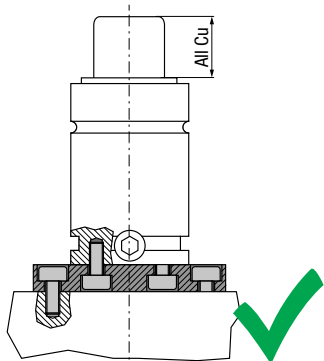

Installation with base flange through fixing screws.

FBE

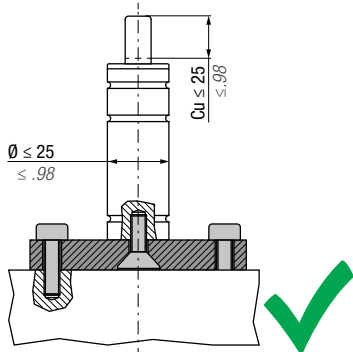

Installation with base flange through single fixing screw.

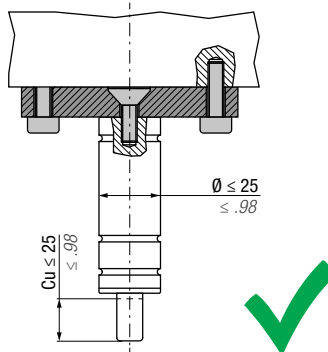

Installation with base flange through single fixing screw in upside down position.

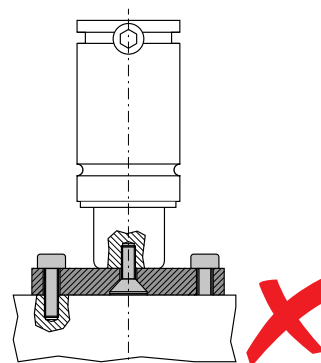

Installation NOT allowed due to excessive stress on screw and internal components.

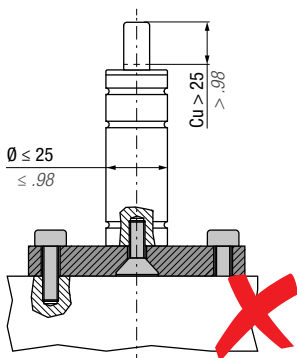

Installation NOT allowed due to excessive stress on gas spring bottom.

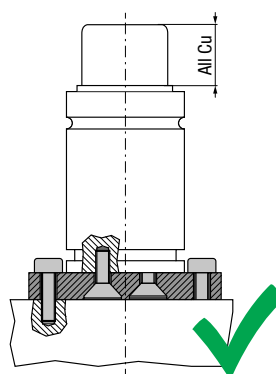
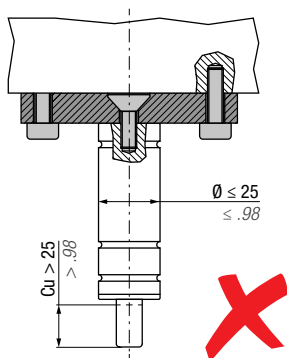

Installation with base flange through fixing screws.

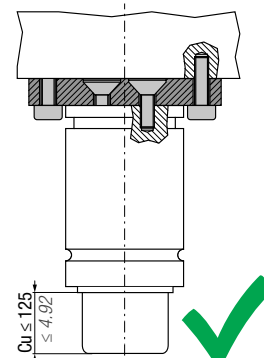

Installation with base flange through fixing screws in upside down position.

All dimensions in mm / inch

INSTALLATION GUIDELINE - TOP MOUNT



Esempi di installazione - Installation examples - Montagebeispiele - Exemples d'installation - Ejemplos de instalación - Exemplo de instalação

FCB - FCD - FC - FCC - FCQ - FCQC - FCQB

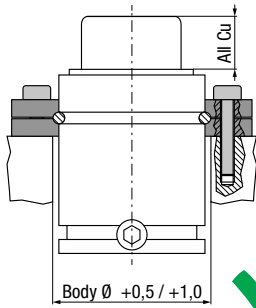

Installation with collar mount flange.

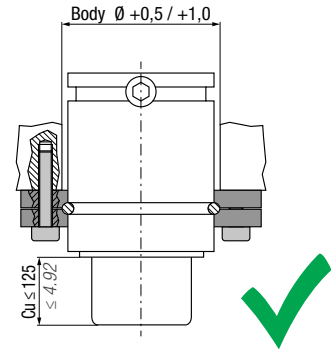
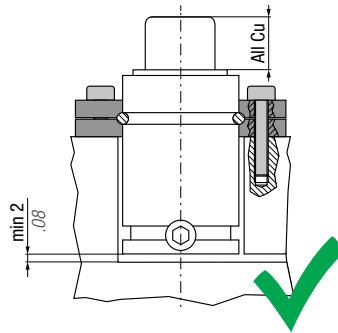

Installation with collar mount flange in upside down position.

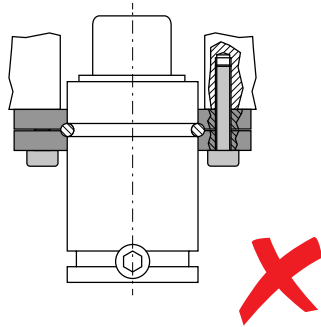

Installation NOT allowed due to tensile stress on screws.

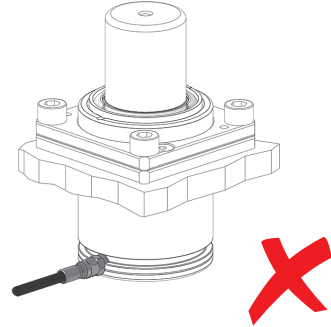
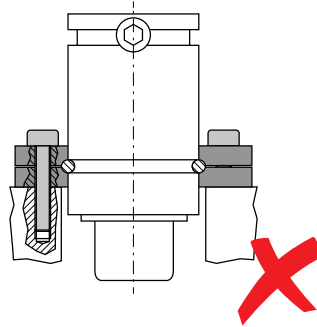

Installation NOT allowed due to risk of gas spring rotation and hose damage.

FC (for body gas spring Ø 12 ÷ 25)

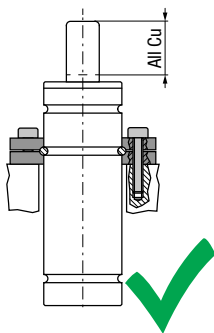

Installation with collar mount flange.

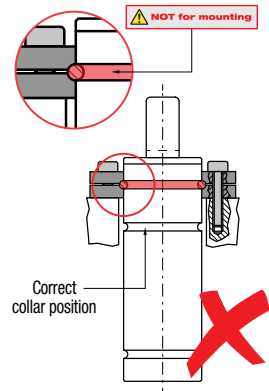
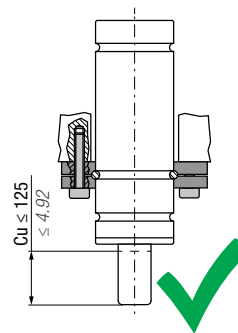
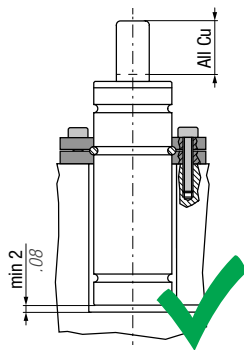

Installation NOT allowed due to excessive stress on internal component (wrong groove).

Esempi di installazione - Installation examples - Montagebeispiele - Exemples d'installation - Ejemplos de instalación - Exemplo de instalação

FS2 - FS2B - FS2A - FS2C

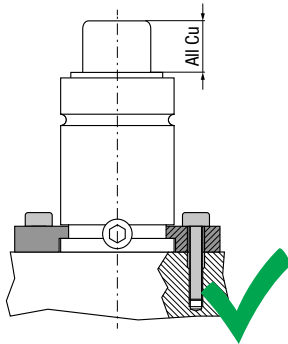

Installation with bracket mount flange.

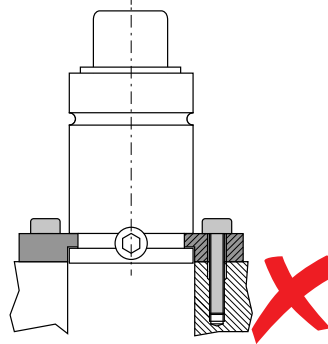

Installation NOT allowed due to excessive stress on gas spring body and flange.

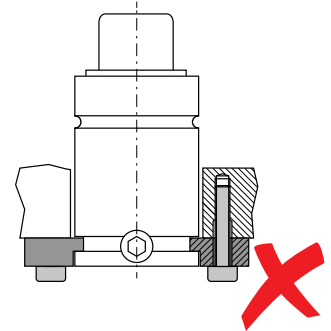

Installation NOT allowed due to tensile stress on screws.

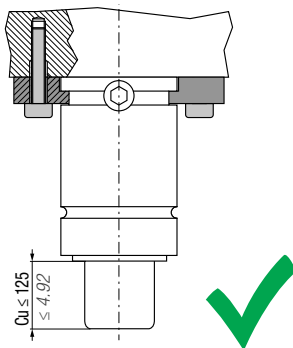

Installation with bracket mount flange in upside down position.

FS1

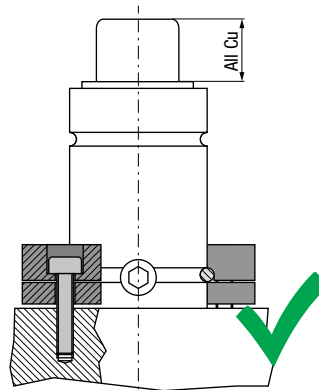

Installation with bracket mount flange.

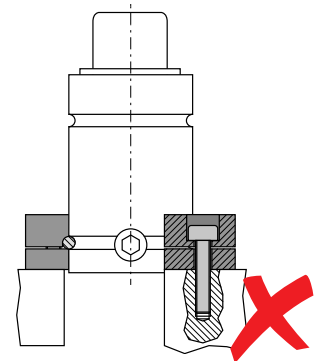

Installation NOT allowed due to excessive stress on gas spring body and flange.

FS3

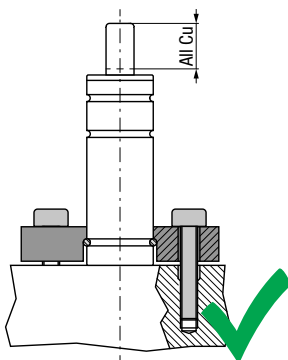

Installation with bracket mount flange.

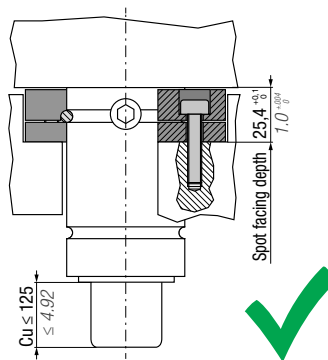

Installation with bracket mount flange in upside down position. Gas spring base must be in contact with upper plate.

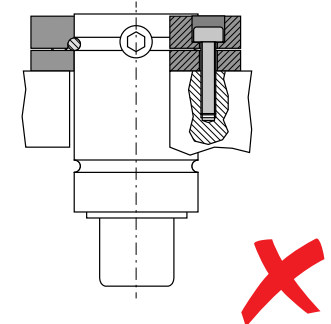

Installation NOT allowed due to tensile stress on screws.

All dimensions in mm /inch

INSTALLATION GUIDELINE - BRACKET MOUNT



Esempi di installazione - Installation examples - Montagebeispiele - Exemples d'installation - Ejemplos de instalación - Exemplo de instalação

FC (for body gas spring $\varnothing 12 \div 25$)

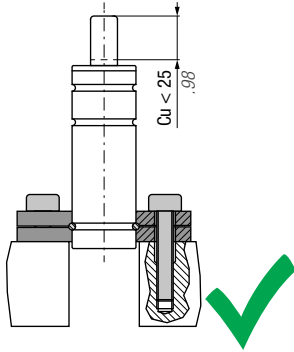

Installation with collar flange on the lower body groove.

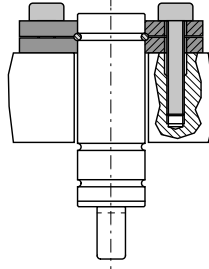

Installation NOT allowed due to tensile stress on screws.

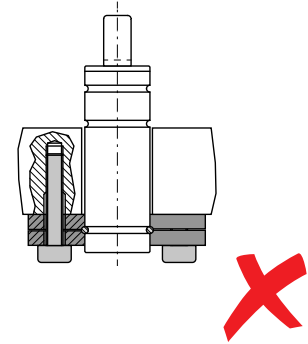

FT

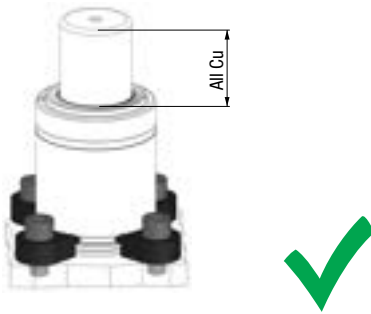

Installation with tooth flange on the lower body groove.

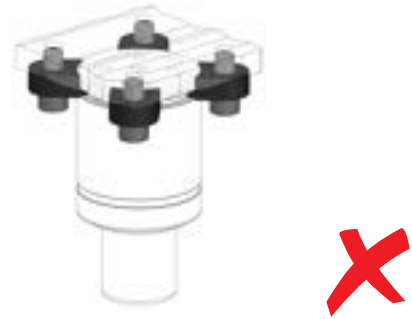

Installation NOT allowed due to risk of die damage in case of screw untightening.

FTP

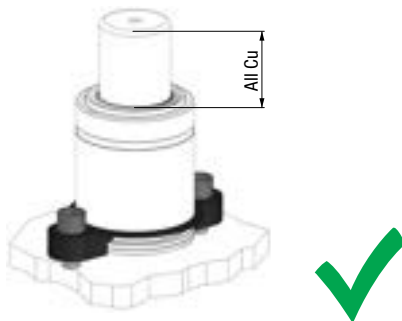

Installation with tooth flange on the lower body groove.

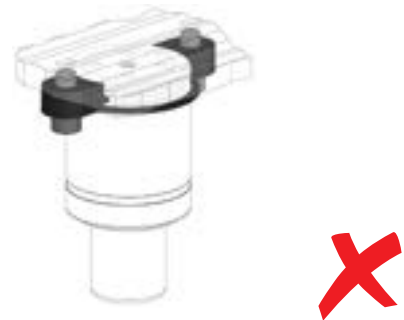

Installation NOT allowed due to risk of die damage in case of screw untightening.

Esempi di installazione - Installation examples - Montagebeispiele - Exemples d'installation - Ejemplos de instalación - Exemplo de instalação

FSA - FSB - FSC - FSD - FSE

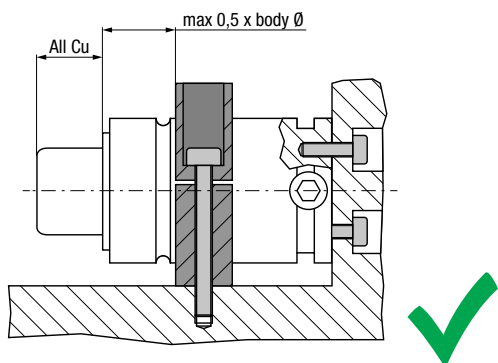

Installation with body mount flange and fixing screws.

(FSA - FSB - FSC - FSD - FSE) + R

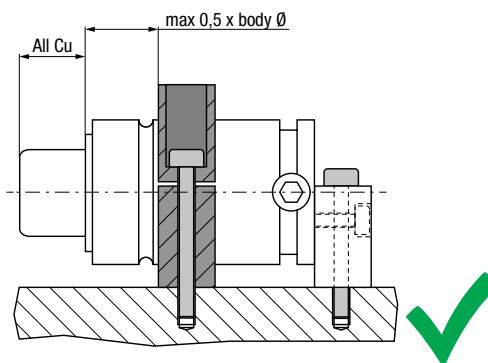

Installation with body mount flange and fixing screws in the rear support.

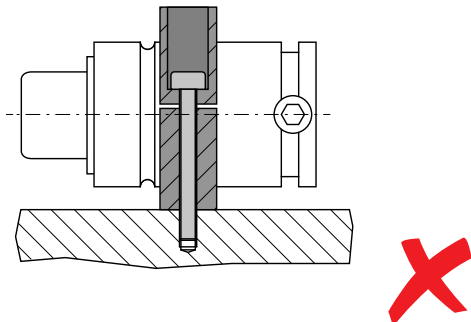

Installation NOT allowed due to lack of reaction force element.

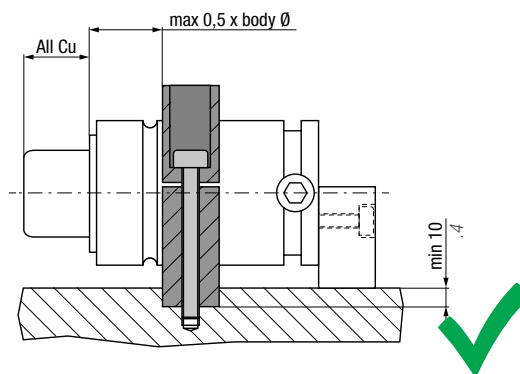

Installation with body mount flange and fixing screws in the rear support.

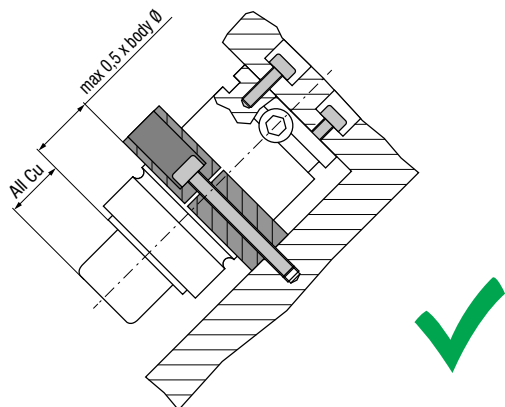

Installation with body mount flange and fixing screws.

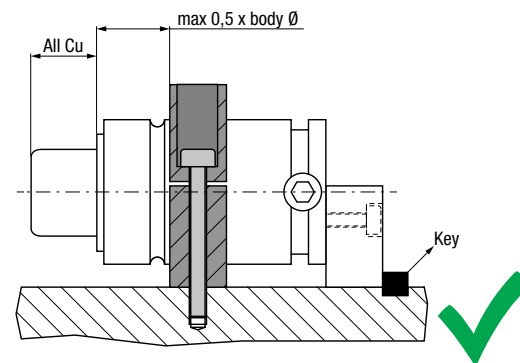

Installation with body mount flange and fixing screws in the key-fixed rear support.

INSTALLATION GUIDELINE - THREAD MOUNT



Esempi di installazione - Installation examples - Montagebeispiele - Exemples d'installation - Ejemplos de instalación - Exemplo de instalação

GM

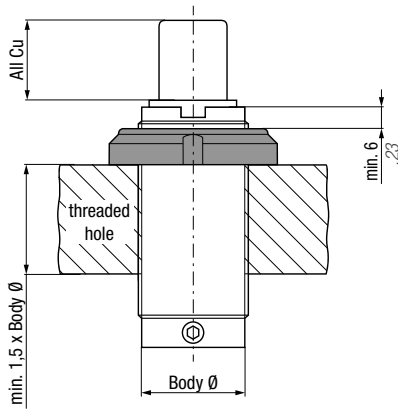

Installation into a threaded hole, locked by a threaded ring.

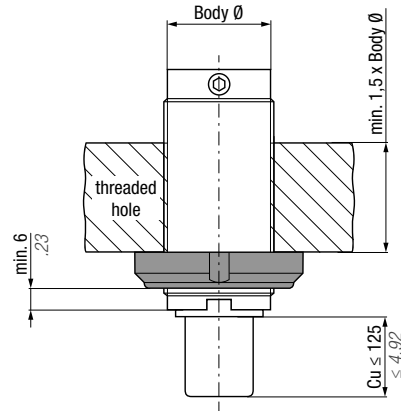

Installation into a threaded hole, locked by a threaded ring in upside down position.

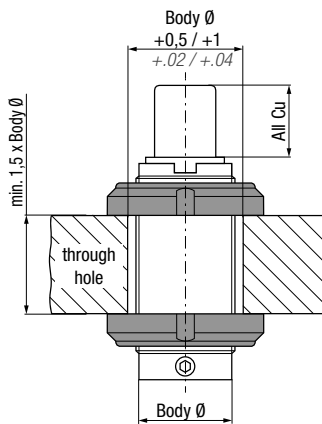

Installation into a through hole, locked by two threaded rings.

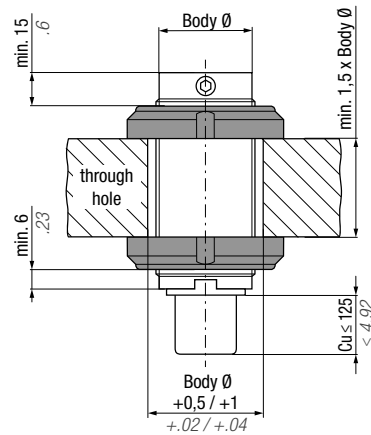

Installation into a through hole, locked by two threaded rings in upside down position.

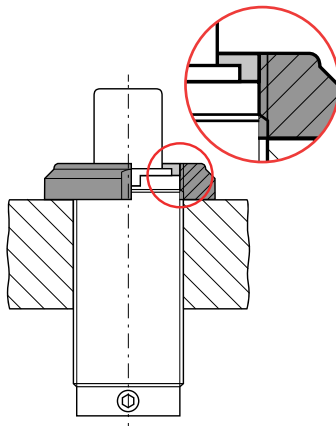

Installation NOT allowed due to insufficient length of engaged thread.

DM - DI

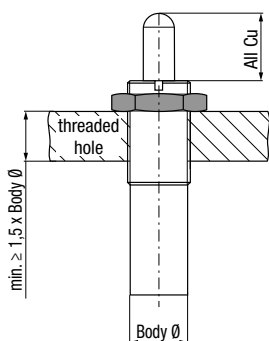

Installation into a threaded hole, locked by a nut.

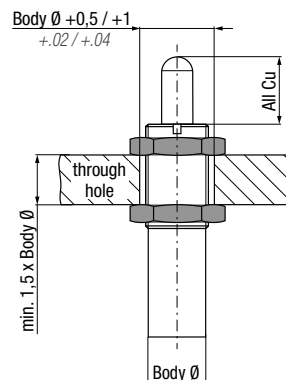

Installation into a through hole, locked by two nuts.

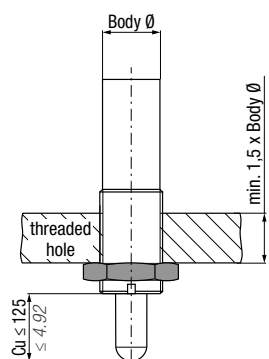

Installation into a threaded hole, locked by a nut in upside down position.

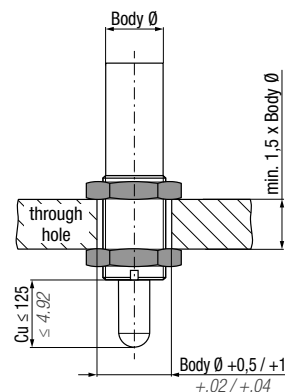

Installation into a through hole, locked by two nuts in upside down position.

INSTALLATION GUIDELINE - THREAD MOUNT



Esempi di installazione - Installation examples - Montagebeispiele - Exemples d'installation - Ejemplos de instalación - Exemplo de instalação

FCA

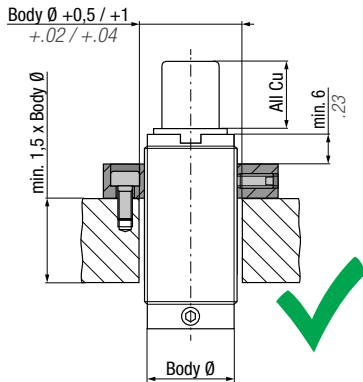

Installation into a through hole, fixed by a top mount threaded flange.

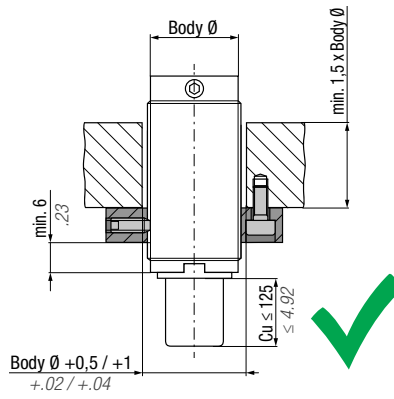

Installation into a through hole, fixed by a top mount threaded flange in upside down position.

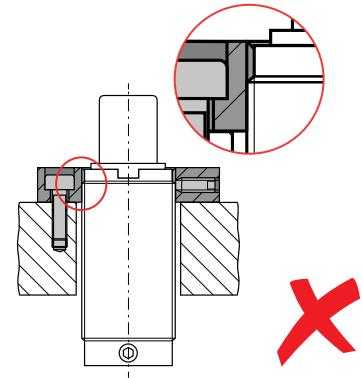

Installation NOT allowed due to insufficient engaged thread strength.

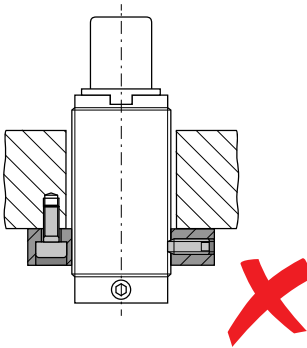

Installation NOT allowed due to tensile stress on screws.

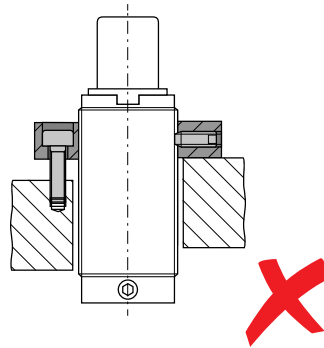

Installation NOT allowed due to off-axis positioning.

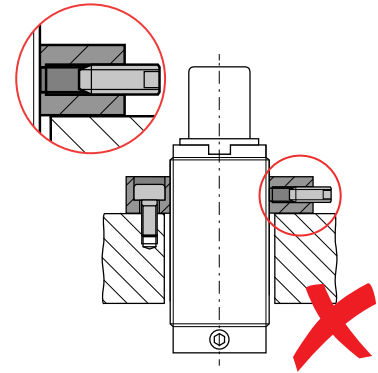

Installation NOT allowed due to gas spring untightening.

Esempi di installazione - Installation examples - Montagebeispiele - Exemples d'installation - Ejemplos de instalación - Exemplo de instalação

- IT** Installare i cilindri ad azoto rispettando le indicazioni fornite qui sotto. Informazioni dettagliate sono presenti nel kit dedicato.
- EN** Install the gas springs following the directions given here below. Detailed information is included in the specific kit.
- DE** Montieren Sie die Gasdruckfedern gemäß den unten folgenden Anweisungen. Detaillierte Anweisungen finden Sie im jeweiligen Bausatz.
- FR** Installez les ressorts à gaz en suivant les instructions données ci-dessous. Des informations détaillées sont incluses dans le kit spécifique.
- ES** Instale los cilindros de gas siguiendo las instrucciones facilitadas a continuación. Información detallada incluida en el kit correspondiente.
- PT** Fixar os cilindros respeitando as orientações abaixo. Todas as informações detalhadas estão presentes no manual de instruções de cada cilindro.

ML, MP, MQ series - SELF CONTAINED

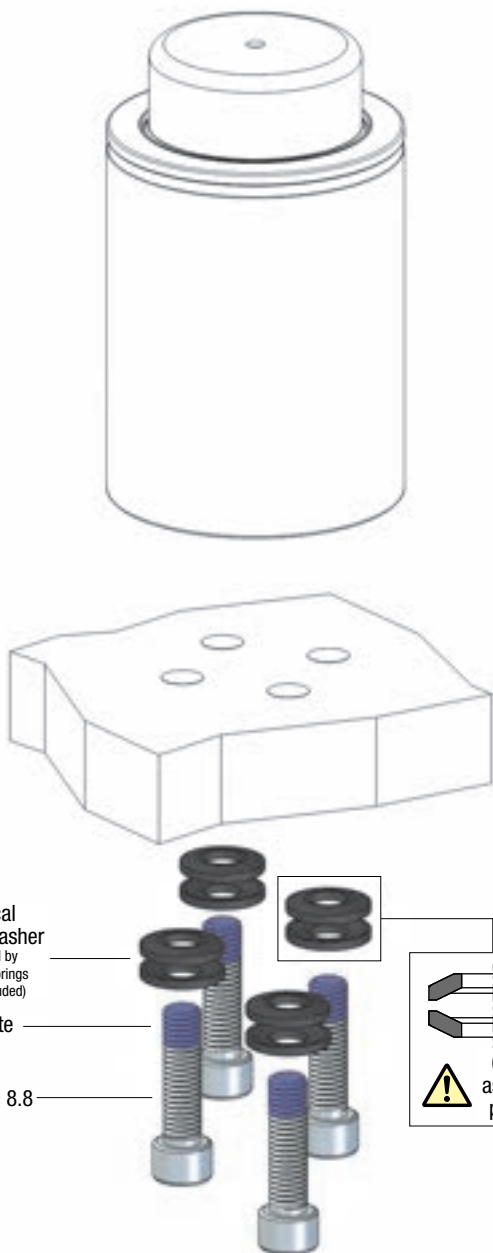

ML - LINKABLE

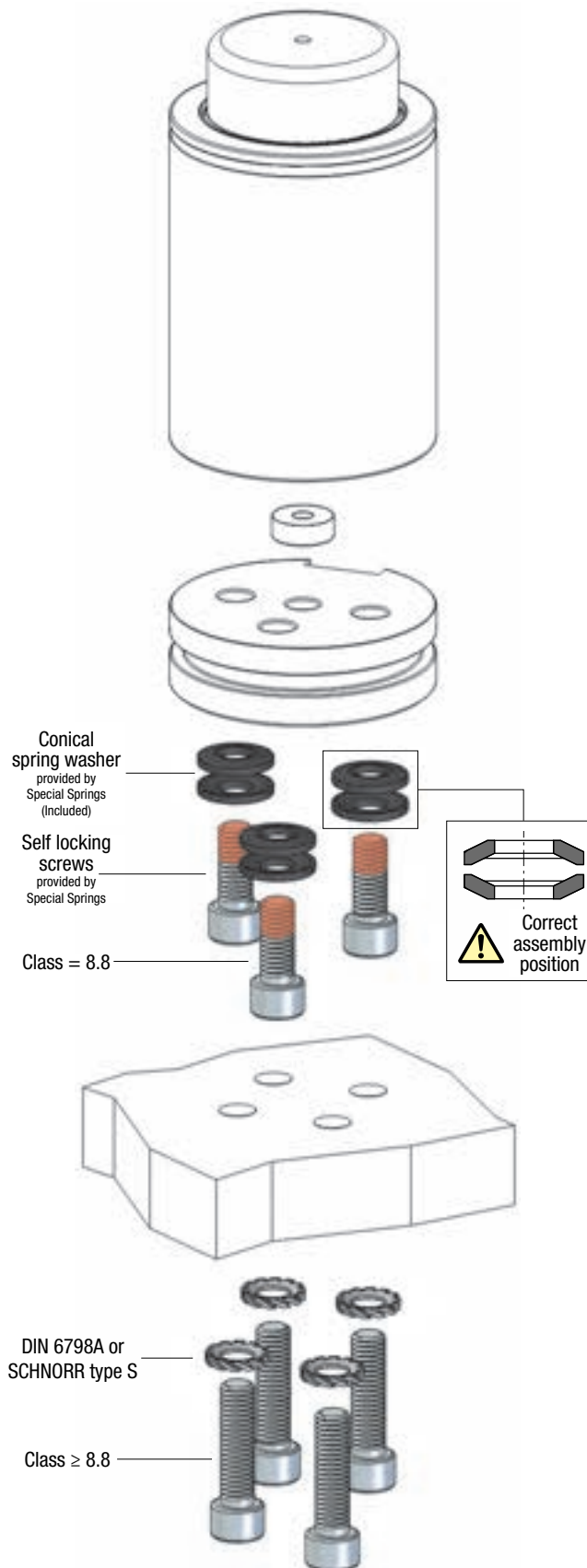

INSTALLATION GUIDELINE - ML, MP, MQ series



Esempi di installazione - Installation examples - Montagebeispiele - Exemples d'installation - Ejemplos de instalación - Exemplo de instalação

ML - EASY MANIFOLD

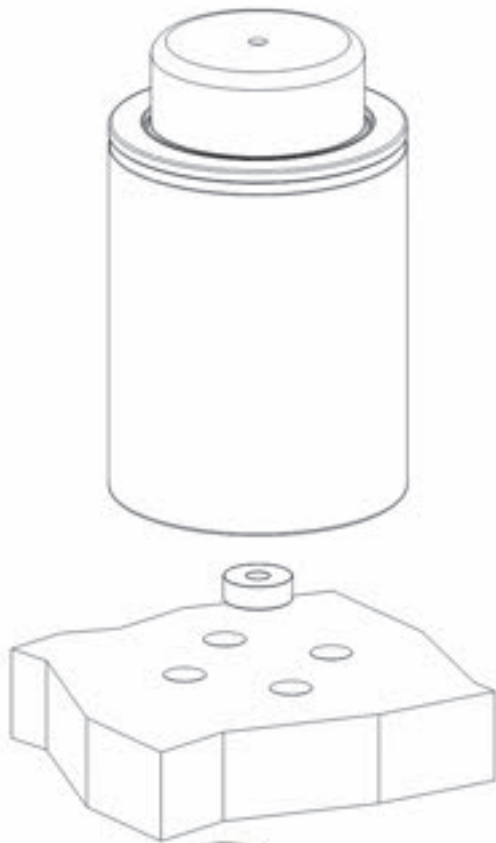

Conical spring washer provided by Special Springs (Included)

Loctite

Class = 8.8

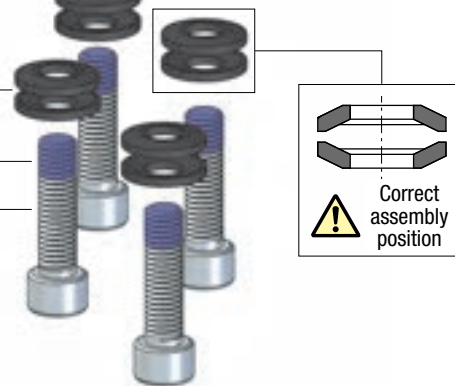

FIXING INFORMATION

- IT** Si raccomanda di installare i cilindri ad azoto nelle versioni "Self Contained" e "Easy Manifold" rispettando le indicazioni qui sotto.
- EN** It is recommended to install gas springs in the "Self-Contained" and "Easy Manifold" versions by following the directions given here below.
- DE** Es wird empfohlen, die Gasdruckfedern der Versionen "Self-Contained" und "Easy Manifold" gemäß den unten aufgeführten Anweisungen einzubauen.
- FR** Il est recommandé d'installer les ressorts à gaz dans les versions "Self-Contained" (autonome) et "Easy Manifold" en suivant les instructions données ci-dessous.
- ES** Se recomienda instalar los cilindros de gas en las versiones "Self-Contained" (autónomo) y "Easy Manifold" siguiendo las instrucciones facilitadas a continuación.
- PT** Se recomenda fixar os cilindros **autonomos** e os para "Easy Manifold", conforme as instruções abaixo.

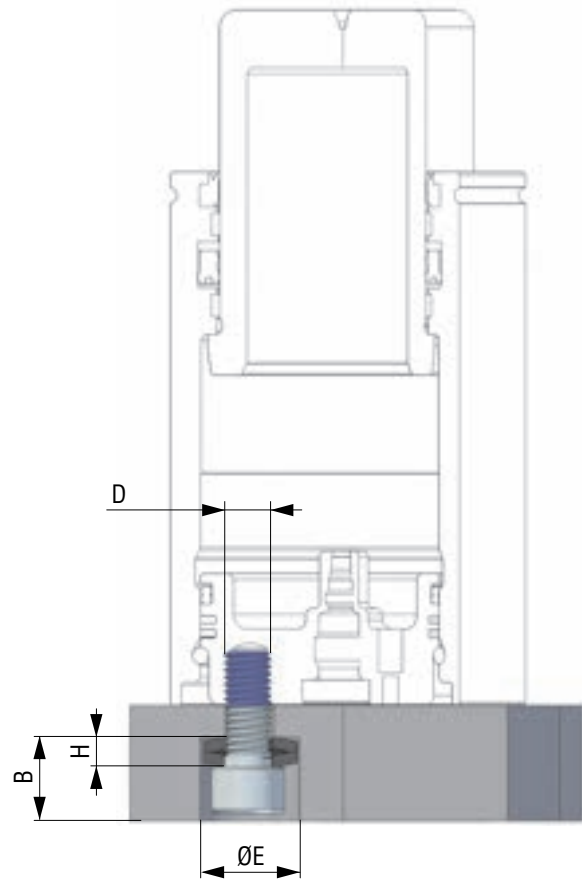

Model	Conical spring washer code	Ø E		B		H		D	 UNI EN ISO 21269:2007 class = 8.8
		mm	inch	mm	inch	mm	inch		
ML 1000 D / ML 1800 D MP 500 A / MP 1000 A MQ 700 A	49RC06A	≥ 10,25	≥ .40	≥ 9,15	≥ .36	3,15	.12	M6	
ML 3000 D	49RCHS08A	≥ 17,3	≥ .68	≥ 12	≥ .47	4	.16	M8	
ML 4700 D / ML 7500 D MP 2000 A / MP 3000 A	49RC08A	≥ 18,3	≥ .72	≥ 12	≥ .47	4	.16	M8	
ML 12000 D	49RC10A	≥ 23,3	≥ .92	≥ 15	≥ .59	5	.20	M10	